

NOTE THIS PLAN IS FOR DISCUSSION PURPOSES ONLY. SUBJECT TO FINAL SURVEYS, DESIGN, ENGINEERING, AND REGULATORY REVIEW

**PROJECT NOTES:**  
 REDUCES PEDETRIAN/VEHICLES CONFLICTS ON BANK STREET.  
 NEW 8 FOOT SIDEWALK THAT CONNECTS SIMS PARK TO MAIN STREET.

**PARKING DATA:**

**PROPOSED = 123 SPACES**  
 STANDARD (9x18) 79 SPACES  
 COMPACT (8x16) 22 SPACES  
 HANDICAP (12x18) 8 SPACES  
 ON STREET (10x20) 14 SPACES

**EXISTING = 88 SPACES**  
 RANDOM SPACE SIZES

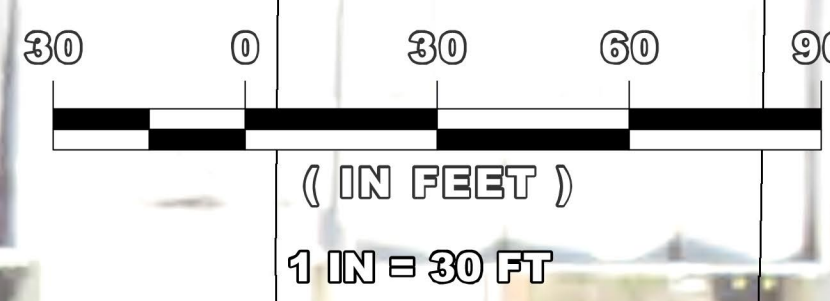

# Lot 4: Bank St Lot

GSI, LLC dba Genesis Group  
1000 N Ashley Dr, Suite 900  
Tampa, FL 33602  
(813) 620-4000  
www.GenesisGroup.com  
Landscape Architecture  
LPA 0000000

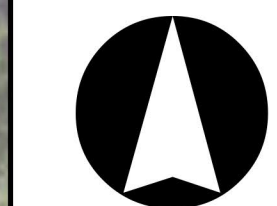

**GENESIS**  
FROM VISION TO REALITY  
Engineering :: Landscape Architecture :: Planning :: GIS

2017 FDOT IMAGERY  
PASCO COUNTY, FL