



Name: 4" Compressor-Assisted Solids Handling Pump

Model: 4JSCM

With its heavy-duty cast-iron construction and fast priming capabilities, the Thompson 4JSCM solids handling end suction centrifugal pump leads the industry in construction, industrial and municipal applications. The Thompson 4JSCM is designed for moderate flows up to 1,225 gpm and heads up to 120 feet making it perfect for sewage bypass pumping or general construction dewatering.

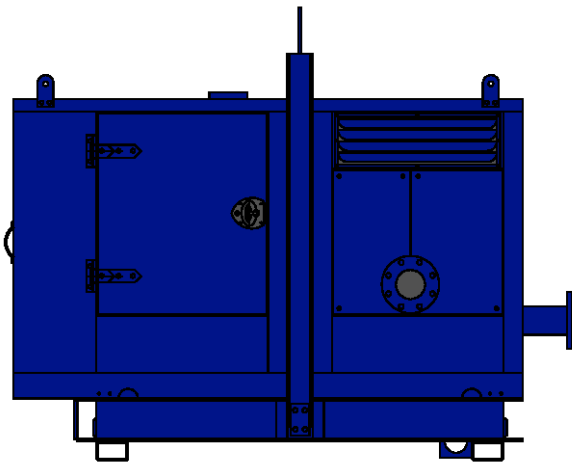

Photo shown may not be exact model.

Consult factory for other versions & options including site trailers, sound attenuation, etc.

Pump End Materials	
Pump Casing	Heavy-duty class 30 ductile-iron.
Impeller	Dynamically balanced, non-clogging, open, 65-45-12 ductile iron with rear-equalizing vanes to reduce axial loading and prolong seal and bearing life; diameter 8.25".
Mechanical Seal	Dry-running, grease or oil lubricated with Tungsten Carbide rotating and Silicon Carbide stationary seal faces. Single inside mounted, non- pusher type with self-adjusting elastomeric bellows. Other components are 304 stainless steel and Viton.
Head	Rugged, back pull out design, heavy-duty class 30 cast iron with tapered bore design.
Bearings	Heavy-duty grease lubricated to carry both axial and radial loads.
Bearing Frame	Heavy-duty class 30 ductile iron.
Shaft	SAE 1144 fitted with 416 stainless steel shaft sleeve.

Technical Specifications			
Suction Size	4 in (10.16 cm)	Approximate Dry Weight	4,560 lbs (2,068.38 kg)
Discharge Size	4 in (10.16 cm)	Best Efficiency	71%
Maximum Solids Handling	3 in (7.62 cm)	Maximum Operating Speed	2,400 rpm
Maximum Operating Temperature	200° F (93.33° C)	Maximum Operating Pressure	58.44 psi (402.94 kPa)

Fuel Tank Options*		Isuzu	Deutz
Modular (M)	100 Gal	100 Hours	99 Hours
Double-Wall (D)	75 Gal	75 Hours	74 Hours
Modular Large Capacity (X)	150 Gal	151 Hours	149 Hours
Double-Wall Large Capacity (Z)	150 Gal	151 Hours	149 Hours

*Contact factory for fuel tank sizes not listed above.

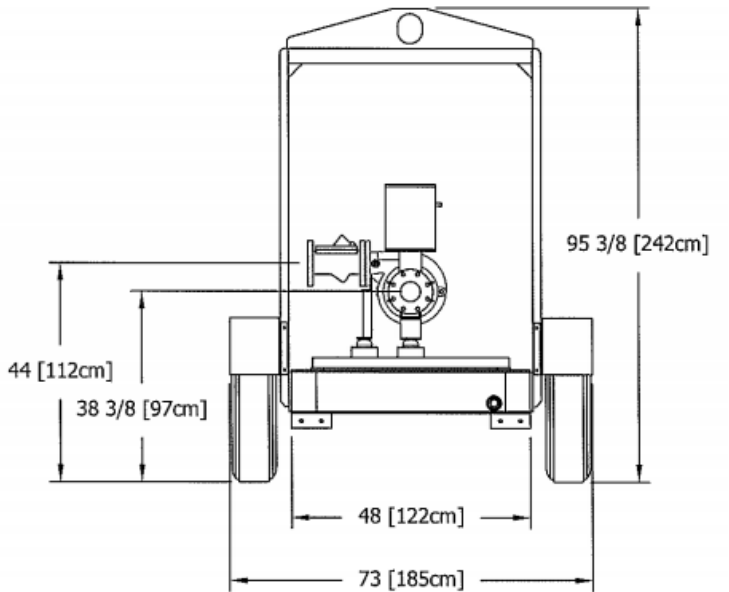
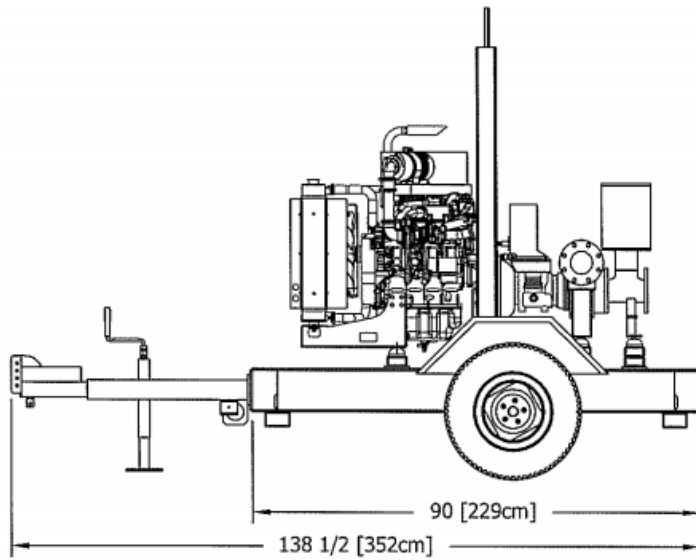
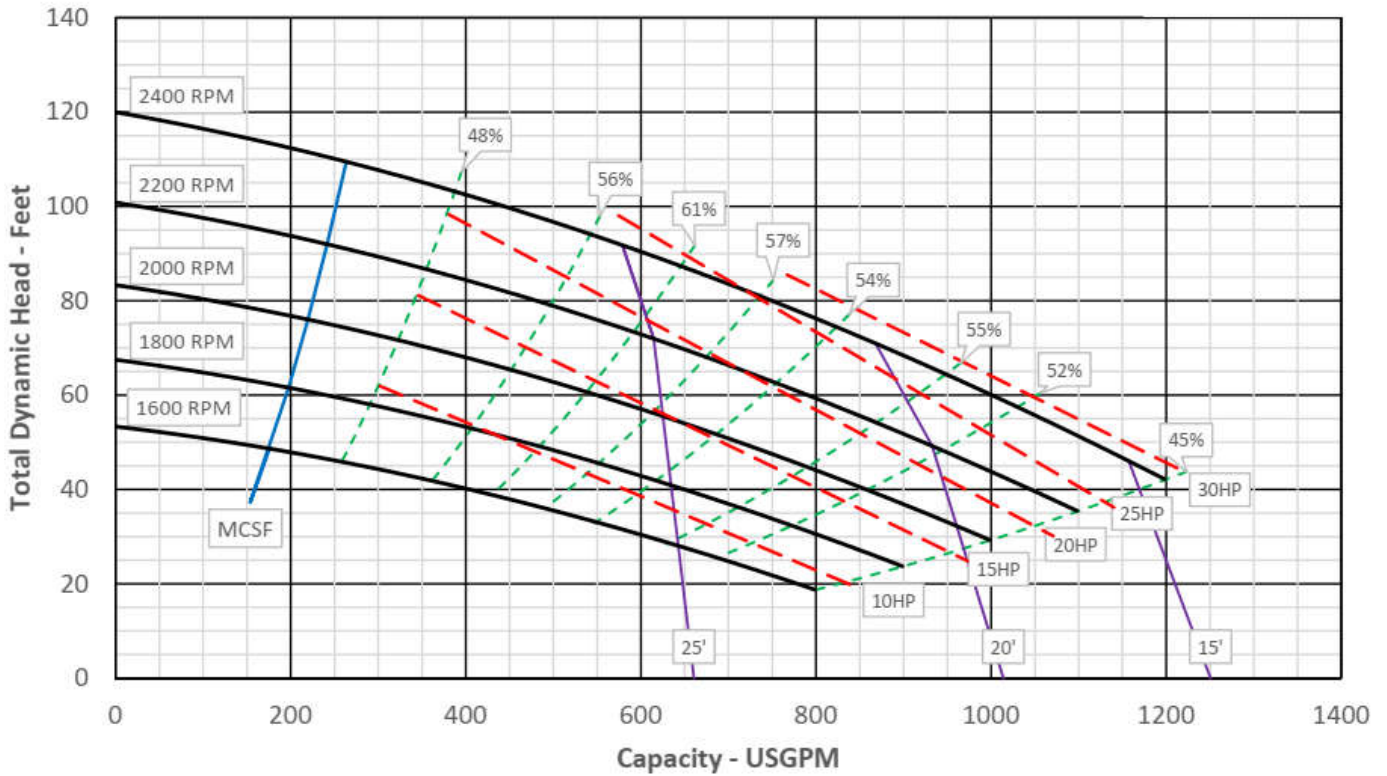

Isuzu 4LE2T—43 hp @ 2,400 rpm

Typical Operating Speed	2,400 rpm	Engine Speed	2,400 rpm	Fuel Economy	0.411 lb/hp-hr	Run Time*	47 hrs
Maximum Head	135 ft (22.86 m)	2,400 rpm	0.390 lb/hp-hr	66 hrs			
Maximum Flow Capacity	1,350 gpm (493.72 m ³ /hr)	2,200 rpm	0.387 lb-hp-hr	100 hrs			
Maximum Fuel Consumption	2.11 gph (7.99 L/hr)	2,000 rpm					

Deutz D2.9L4— 40 hp @ 2,400 rpm

Typical Operating Speed	2,400 rpm	Engine Speed	2,400 rpm	Fuel Economy	0.420 lb/hp-hr	Run Time*	46 hrs
Maximum Head	135 ft (22.86 m)	2,400 rpm	0.405 lb/hp-hr	64 hrs			
Maximum Flow Capacity	1,350 gpm (493.72 m ³ /hr)	2,200 rpm	0.390 lb-hp-hr	99 hrs			
Maximum Fuel Consumption	2.16 gph (8.18 L/hr)	2,000 rpm					

*Engine run times calculated based on a 100 gallon fuel tank.

Specifications and illustrations are subject to revision without notice and without incurring any obligation for previous or subsequent equipment sold. Thompson Pump (ISO 9001:2015) makes no representation regarding the completeness or accuracy of this information and is not liable for any direct or indirect damages arising from or relating to this information or its use. Capacity & Head are shown for comparative purposes. Consult Thompson factory for exact capabilities.